

# WiMOD iM880A

Datasheet

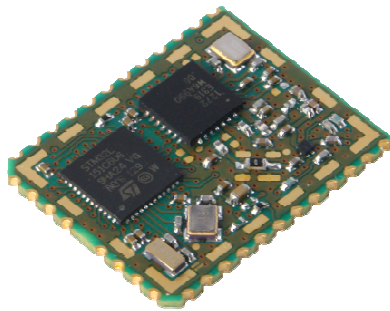

Document ID: 4100/40140/0063

---

**IMST GmbH**

Carl-Friedrich-Gauß-Str. 2-4

47475 KAMP-LINTFORT

GERMANY



## Document Information

<b>File name</b>	iM880A_Datasheet.docx
<b>Created</b>	2013-07-25
<b>Total pages</b>	26

## Revision History

<b>Version</b>	<b>Note</b>
0.1	Created, Temporary Version
0.2	Still Temporary Version
0.5	First released
0.6	Modells iM880A-M and iM880A-L added.
0.7	TX performance update
0.8	Table 4-2 update
1.0	Chapter 5.3 update
1.1	Table 5-1: 5 V tolerance abilities added

## Aim of this Document

The aim of this document is to give a detailed product description including interfaces, features and performance of the radio module iM880A.



## Table of Contents

<b>1. INTRODUCTION</b>	<b>4</b>
1.1 Key Features	4
1.2 Applications	4
<b>2. MODULE OVERVIEW</b>	<b>5</b>
<b>3. LORA MODULATION TECHNIQUE</b>	<b>6</b>
<b>4. ELECTRICAL CHARACTERISTICS</b>	<b>7</b>
4.1 Absolute Maximum Ratings	8
4.2 Global Electrical Characteristics	9
4.3 Module Interface Characteristics	10
4.4 RF Characteristics	11
4.4.1 Applicable Frequency Bands and Sub-Bands	11
4.4.2 Transmitter RF Characteristics	12
<b>5. MODULE PACKAGE</b>	<b>13</b>
5.1 Pinout Description	13
5.2 Module Dimensions	16
5.3 Recommended Footprint	16
<b>6. MODULE INTERFACE CHARACTERISTICS</b>	<b>17</b>
6.1 Programming Interface	17
<b>7. INTEGRATION GUIDE</b>	<b>18</b>
7.1 Typical Application Schematic	18
7.2 PCB Design Recommendation	19
7.3 Recommended Soldering Conditions	20
<b>8. ORDERING INFORMATION</b>	<b>21</b>
<b>9. APPENDIX</b>	<b>22</b>
9.1 List of Abbreviations	22
9.2 List of Figures	23
9.3 List of Tables	23
9.4 References	23
<b>10. REGULATORY COMPLIANCE INFORMATION</b>	<b>24</b>

<b>11. IMPORTANT NOTICE</b>	<b>25</b>
<b>11.1 Disclaimer</b>	<b>25</b>
<b>11.2 Contact Information</b>	<b>25</b>



# 1. Introduction

The iM880A is a compact, low power, bidirectional radio module for the 868 MHz frequency band using semtech's LoRa™ modulation technology. The module provides ultra-long range spread spectrum communication and high interference immunity whilst minimising current consumption. Using the iM880A in an application minimizes the need for an expensive and time-consuming RF development. Fast time to market is possible with this pre-qualified module.



Figure 1-1: Picture of iM880A

## 1.1 Key Features

- Compact module 20.0 x 25.0 x 2 mm
- LoRa™ modulation technology
- Sensitivity down to -137 dBm
- UART, SPI and I<sup>2</sup>C interface<sup>1</sup>
- Digital inputs and outputs
- Analog inputs
- Supply voltage range from 2.4 to 3.6 V
- RF interface optimized to 50 Ω
- Output power level up to +19 dBm
- High link budget up to 156 dB
- Range up to 15000m (Line of Sight)
- STM32L151Cx
- Pre-Certified according to EN 300 220

## 1.2 Applications

- Automated Meter Reading
- Wireless Networks
- Home-, Building-, Industrial automation
- Remote Control
- Wireless Sensors
- Telemetry
- Wireless Alarm and Security Systems
- ...

Please visit our web site [www.wireless-solutions.de](http://www.wireless-solutions.de) for more information.

---

<sup>1</sup> Default host controller interface is UART. SPI and I<sup>2</sup>C functionality available on request.

## 2. Module Overview

The iM880A is an ultra-long range, high-performance, pre-certified module for wireless communication. It operates in the license free 868 MHz SRD frequency band and includes all necessary passive components for wireless communication as depicted in the following figure.

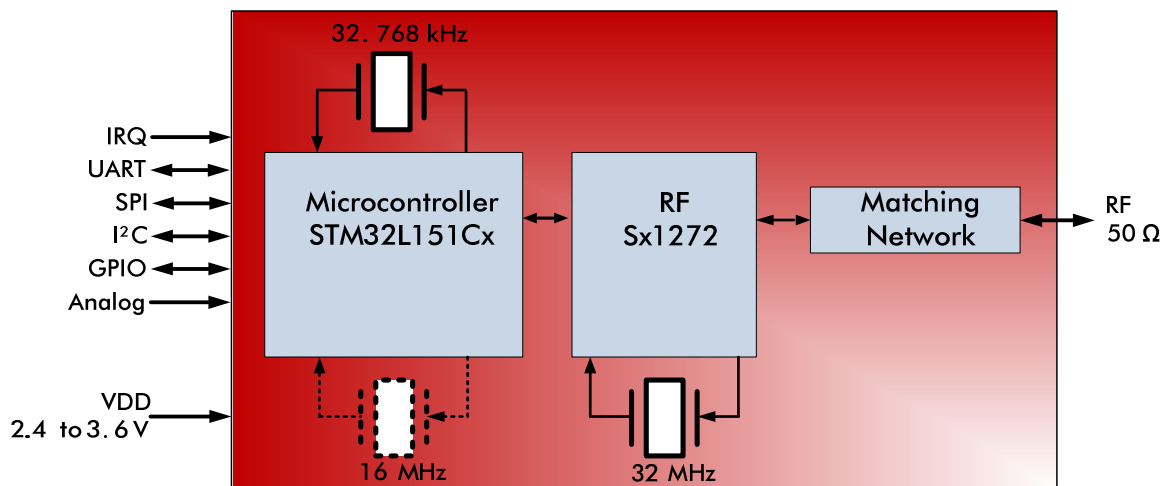

Figure 2-1: Block Diagram of Radio Module iM880A

The iM880A uses Semtech’s patented LoRa modulation technique which combines spread spectrum modulation and forward error correction techniques to increase the range and robustness of radio communication links compared with traditional FSK or OOK based modulation. Typically examples of iM880A receive performances are given in the following table.

Signal Bandwidth/[kHz]	Spreading Factor	Sensitivity/[dBm]
125	7	-123
125	12	-138
250	7	-121
250	12	-135
500	7	-116
500	12	-130

Table 2-1: Typically Radio Performance of iM880A

This high sensitivity combined with the integrated +19 dBm power amplifier yields industry leading link budget.

The module is solderable like a SMD component and can easily be mounted on a simple carrier board with a minimum of required external connections. It is RoHS compliant and pre-qualified in accordance to ETSI EN 300 220-2 V2.1.2.

The wide range of capabilities provided by the iM880A can be tested by using the WiMOD Demo Board (part of the WiMOD Starter Kit).



### 3. LoRa Modulation Technique

The iM880A uses Semtech's LoRa proprietary spread spectrum modulation technique. This modulation, in contrast to conventional modulation techniques, permits an increase in link budget and increased immunity to in-band interference. It achieves sensitivities 8 dB better than FSK modulation.

LoRa also provides significant advantages in both blocking and selectivity, solving the traditional design compromise between range, interference immunity and energy consumption.

In LoRa mode the iM880A offers three bandwidth options of 125 kHz, 250 kHz, and 500 kHz with spreading factors ranging from 7 to 12.

The spread spectrum LoRa modulation is performed by representing each bit of payload information by multiple chips of information. The rate at which the spread information is sent is referred to as the symbol rate ( $R_s$ ), the ratio between the nominal symbol rate and chip rate is the spreading factor and represents the number of symbols sent per bit of information. The range of parameters which can be configured are given in the following tables.

Spreading Factor	Chips/Symbol	SNR/[dB]
7	128	-7.5
8	256	-10
9	512	-12.5
10	1024	-15
11	2048	-17.5
12	4096	-20

Table 3-1: Spreading Factors of Sx1272

Note that the spreading factor must be known in advance on both transmit and receive sides of the radio link as different spreading factors are orthogonal to each other. Note also the resulting signal to noise ratio (SNR) required at the receiver input. It is the capability to receive signals with negative SNR that increases the sensitivity, so link budget and range, of the LoRa receiver.

To further improve the robustness of the radio link iM880A provides cyclic error coding with different coding rates. With using this coding scheme forward error detection and correction can be applied.

Coding Rate	Cyclic Coding Rate	Overhead Ratio
1	4/5	1.25
2	4/6	1.5
3	4/7	1.75
4	4/8	2

Table 3-2: Coding Rate of iM880A

## 4. Electrical Characteristics

In the following different electrical characteristics of the iM880A are listed. Furthermore details and other parameter ranges are available on request.

**Note:** Stress exceeding of one or more of the limiting values listed under "Absolute Maximum Ratings" may cause permanent damage to the radio module.



## 4.1 Absolute Maximum Ratings

Parameter	Condition	Min	Typ.	Max	Unit
Supply Voltage (VDD)		-0.3	-	3.9	V
Storage Temperature		-40	-	+85	°C
Operating Temperature		-20	-	+70	°C
RF Input Power				+10	dBm
ESD (Human Body Model)			2000		V
ESD (Charge Device Model)			500		V
Notes: 1) Unless otherwise noted, all voltages are with respect to GND					

Table 4-1: Absolute Maximum Ratings

**Note:** With RF output power level above +16 dBm a minimum distance between two devices should be 1 m for avoiding too large input level.

## 4.2 Global Electrical Characteristics

T = 25°C, VDD = 3.0 V (typ.) if nothing else stated

Parameter	Condition	Min	Typ.	Max	Unit
Supply Voltage (VDD)	Note 1	2.4	3.0	3.6	V
Current Consumption Low Power Mode	RTC off		680		nA
	RTC on		1.8		μA
Current Consumption System IDLE	TRX idle mode, μC idle mode		5		mA
Current Consumption RECEIVE LoRa	TRX receive mode, μC sleep mode		11.2		mA
Current Consumption TRANSMIT <sub>(Note 3)</sub>	TRX transmit mode, μC sleep mode, all μC units off, max. RF power level	117	122	126	mA
MCU operation frequency			32		MHz
			32.768		kHz
Memory (Flash)	iM880A-L		128		kByte
	iM880A-M		64		
Flash Memory Endurance	Program memory	10			Erase/ Write Cycles
	Data memory	300			
Memory (RAM)	iM880A-L		16		kByte
	iM880A-M		10		
Notes:					
1) Lab Sample iM880A-B100 has a maximum voltage of 3.3 V, for B101 and later 3.6 V is possible					
2) Unless otherwise noted, all voltages are with respect to GND					
3) @ 866.5 MHz, 25°C					

Table 4-2: General Characteristics

### 4.3 Module Interface Characteristics

T = 25°C, VDD = 3 V (typ.) if nothing else stated

Parameter	Condition	Min	Typ.	Max	Unit
Digital output voltage (high level)	VDD = 2.4 V to 2.7 V, 8 pins max. at the same time, 4 mA (max)	VDD -0.45			V
	VDD = 2.7 V to 3.6 V, 8 pins max. at the same time, , 8 mA (max)	2.4			
Digital output voltage (low level)	VDD = 2.4 V to 2.7 V, 8 pins max. at the same time, 4 mA (max)			0.45	V
	VDD = 2.7 V to 3.6 V, 8 pins max. at the same time, , 8 mA (max)			0.4	
Digital input voltage (high level)	VDD = 2.4 V to 3.6 V, CMOS			VDD + 0.3	V
	VDD = 2.4 V to 3.6 V, CMOS, 5 V tolerant	0.7 VDD		5.5	V
Digital input voltage (low level)	VDD = 2.4 V to 3.6 V, CMOS	-0.3		0.3 VDD	V
UART baud rate			115.2		kbps
Notes:					
1) Unless otherwise noted, all voltages are with respect to GND					

Table 4-3: Module Interface Characteristics

## 4.4 RF Characteristics

### 4.4.1 Applicable Frequency Bands and Sub-Bands

Following table depicts the applicable frequency bands within the 868 MHz band for “Non-Specific Short Range Devices” specified in the ERC Recommendation 70-03, [2].

Band	Edge Frequencies		Field Power	Spectrum Access	Band Width
g (Note1,2) (Note2) (Note2)	863 MHz	870 MHz	+14 dBm	0.1% or LBT+AFA	7 MHz
	863 MHz	870 MHz	-4.5 dBm / 100 kHz	0.1% or LBT+AFA	7 MHz
	865 MHz	870 MHz	-0.8 dBm / 100 kHz	0.1% or LBT+AFA	5 MHz
	865 MHz	868 MHz	+6.2 dBm / 100 kHz	1% or LBT+AFA	3 MHz
g1	868.0 MHz	868.6 MHz	+14 dBm	1% or LBT+AFA	600 kHz
g2	868.7 MHz	869.2 MHz	+14 dBm	0.1% or LBT+AFA	500 kHz
g3	869.4 MHz	869.65 MHz	+27 dBm	10% or LBT+AFA	250 kHz
g4	869.7 MHz	870 MHz	+14 dBm	1% or LBT+AFA	300 kHz
g4	869.7 MHz	870 MHz	+7 dBm	No requirement	300 kHz
Note1: Modulation bandwidth $\leq 300$ kHz is allowed. Preferred channel spacing is $\leq 100$ kHz.					
Note2: Sub-bands for alarms are excluded (see ERC/REC 70-03 Annex 7).					

Table 4-4: Applicable Frequency Bands for Non-Specific Short Range Devices

**Note:** National laws and regulations, as well as their interpretation can vary with the country. In case of uncertainty, it is recommended to contact either IMST's accredited Test Center or to consult the local authorities of the relevant countries.

For further information about frequency and RF power setting please refer to [4].

### 4.4.2 Transmitter RF Characteristics

The iM880A has an excellent transmitter performance as given by Table 4-5. For further details, refer to Figure 4-1 which gives an overview of RF output power levels versus power level settings and its current consumption with microcontroller in sleep mode.

T = 25°C, VDD = 3 V (typ.), 866.5 MHz if nothing else stated

Parameter	Condition	Min	Typ.	Max	Unit
Frequency Range		863	-	870	MHz
RF Output Power	868 MHz Band		19.0		dBm
Modulation Techniques	LoRa™				
TX Frequency Variation vs. Temperature	-20 to +70°C	-	±7	-	kHz
TX Power Variation vs. Temperature		-	±0.5	-	dB

Table 4-5: Transmitter RF Characteristics

**Note:** The duty cycle of transmission at maximum output power is limited to 1%. The antenna has to be matched with a maximum VSWR of 3:1.

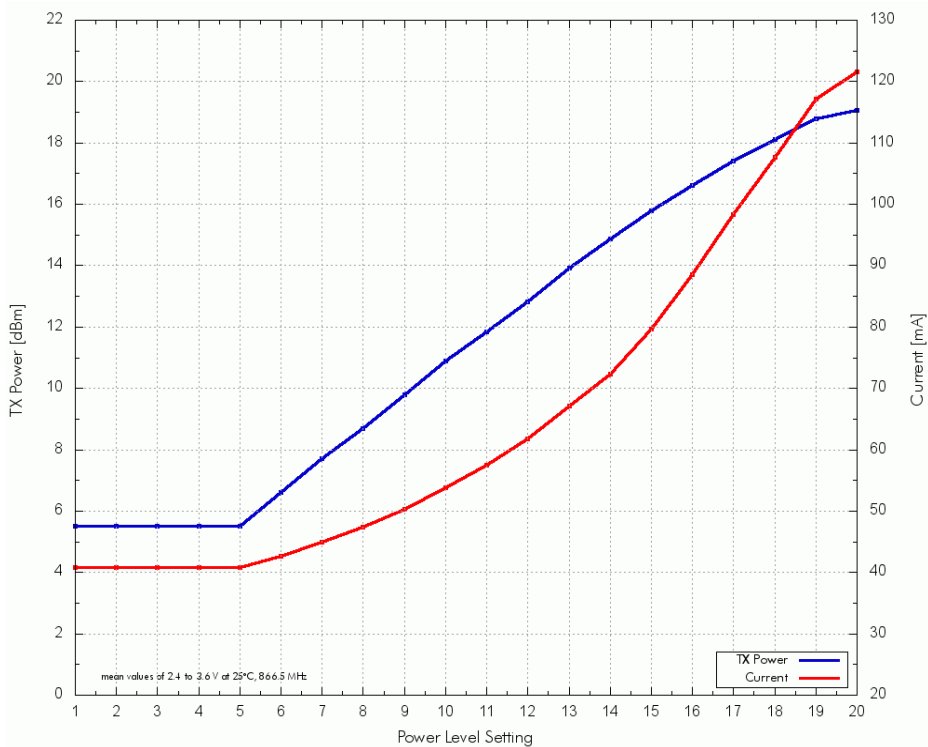

Figure 4-1: RF output power level and current consumption versus power stages from 1 to 20 @ room temperature



## 5. Module Package

In the following the iM880A module package is described. This description includes the iM880A pinout as well as the modules dimensions. Furthermore a recommendation for a suitable footprint is given, which should be used for further mounting on appropriate carrier boards.

### 5.1 Pinout Description

Figure 5-1 depicts a description of the iM880A's pads on the bottom side. The figure shows the module with its pinout in top view (right figure). A detailed description of the individual pins can be found in Table 5-1: iM880A Pinout Table.

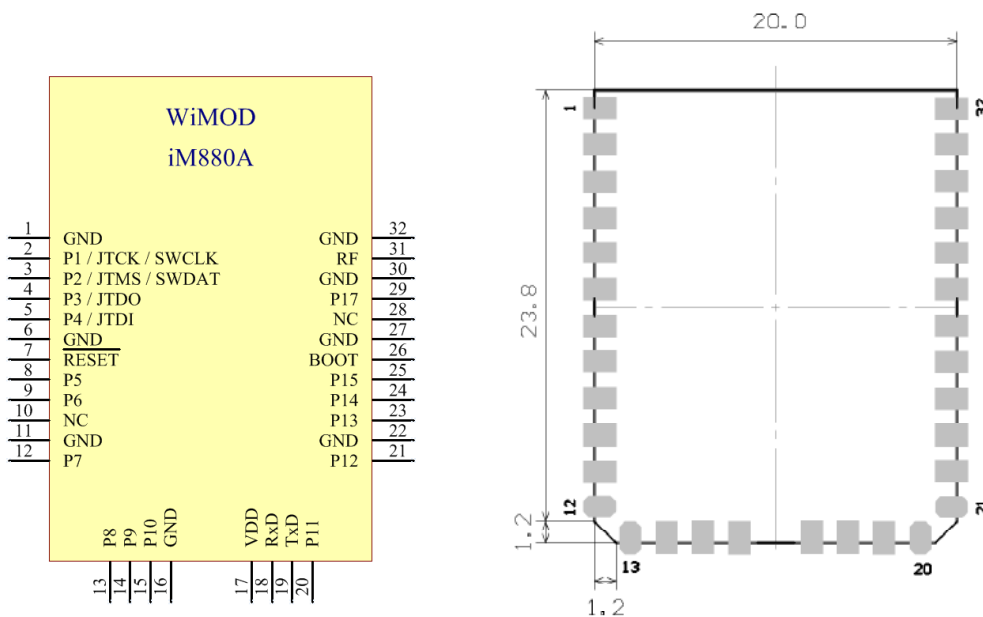

Figure 5-1: Description of iM880A module pins and top view

PIN	PIN Name	PIN Type	MCU Pin (number)	5 V Tolerance	Description
1	GND	Supply		-	Ground connection
2	P1	D IN/OUT	PA_14 (P37)	Yes	Digital IO / JTCK / SWCLK
3	P2	D IN/OUT	PA_13 (P34)	Yes	Digital IO / JTMS / SWDAT
4	P3	D IN/OUT	PB_3 (P39)	Yes	Digital IO / JTDO
5	P4	D IN/OUT	PA_15 (P38)	Yes	Digital IO / JTDI
6	GND	Supply		-	Ground connection
7	nReset	D IN	NRST (P7)	Yes	NReset, internally pulled-up by 47 k $\Omega$
8	P5	D IN/OUT	PA_11 (P32)	Yes	Digital IO / USART1-CTS
9	P6	D IN/OUT	PA_12 (P33)	Yes	Digital IO / USART1-RTS
10	NC	NC		-	This pin should be left unconnected
11	GND	Supply		-	Ground connection
12	P7	D IN/OUT	PB_14 (P27)	No	Digital IO / SPI2_MISO
13	P8	D IN/OUT	PB_15 (P28)	No	Digital IO / SPI2_MOSI
14	P9	D IN/OUT	PB_13 (P26)	No	Digital IO / SPI2_CLK
15	P10	D IN/OUT	PB_12 (P25)	Yes	Digital IO / SPI2_NSS
16	GND	Supply		-	Ground connection
17	VDD	Supply		-	Supply voltage
18	RxD	D IN/OUT	PA_10 (P31) PB_6 (P42)	Yes	Digital IO / USART1-RX Digital IO / TIM4_CH1
19	TxD	D IN/OUT	PA_9 (P30)	No	Digital IO / USART1-TX
20	P11	D IN/OUT	PA_8 (P29)	No	Digital IO
21	P12	D IN/OUT	PB_8 (P45)	Yes	Digital IO / I2C1-SCL
22	GND	Supply		-	Ground connection
23	P13	D IN/OUT	PB_9 (P46)	Yes	Digital IO / I2C1-SDA
24	P14	D IN/OUT, A IN	PA_1 (P11)	No	Digital IO / ADC_IN1
25	P15	D IN/OUT	PA_0 (P10)	No	Digital IO / WKUP1
26	P16	D IN	BOOT0 (P44)	Yes	Bootloader Pin 0, internally pulled-down by 47 k $\Omega$
27	GND	Supply		-	Ground connection
28	NC	NC		-	This pin should be left unconnected
29	P17	D IN/OUT, A IN	PA_3 (P13)	No	Digital IO / ADC_IN3
30	GND	Supply		-	Ground connection

31	RF	A IN/OUT		-	External 50Ω port for monostatic antenna connection
32	GND	Supply		-	Ground connection

*Table 5-1: iM880A Pinout Table*



## 5.2 Module Dimensions

The outer dimensions of the iM880A are given by Figure 5-2 and Figure 5-3.

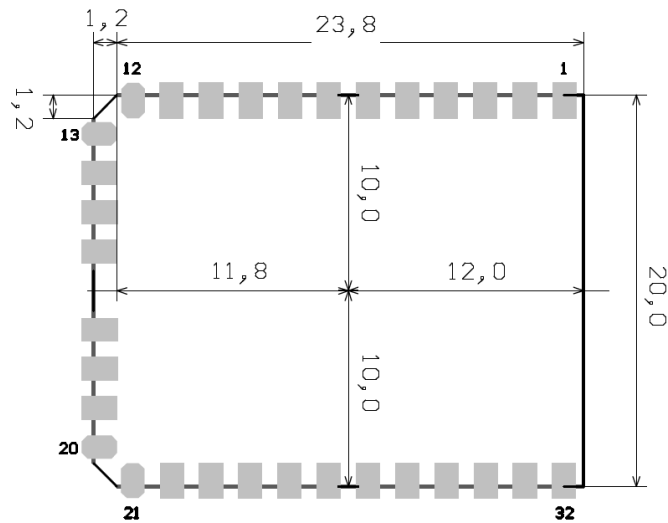

Figure 5-2: Outer Dimensions of the iM880A (top view)

## 5.3 Recommended Footprint

According to Chapter 5.2, a recommendation for the footprint of the iM880A is given by Figure 5-3.

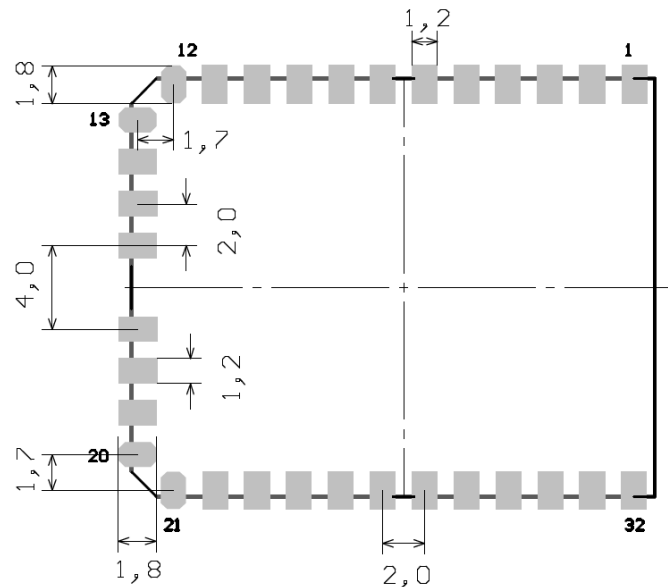

Figure 5-3: Recommended footprint of the iM880A (top view)

## 6. Module Interface Characteristics

### 6.1 Programming Interface

For programming the module with special firmware versions, there are three types of interfaces supported: A JTAG- and a SWD-interface, which require a special programmer, as well as a bootloader-interface, for updating the modules firmware via UART-interface. For more details refer to [\[3\]](#).

## 7. Integration Guide

The iM880A provides 32 connectors as described in Chapter 5. For integrating the iM880A into an environment, a typically circuit as given in Chapter 7.1 can be used. While designing the PCB Layout, the recommendations of Chapter 7.2 should be applied, as well as the recommendation for soldering in Chapter 7.3.

### 7.1 Typical Application Schematic

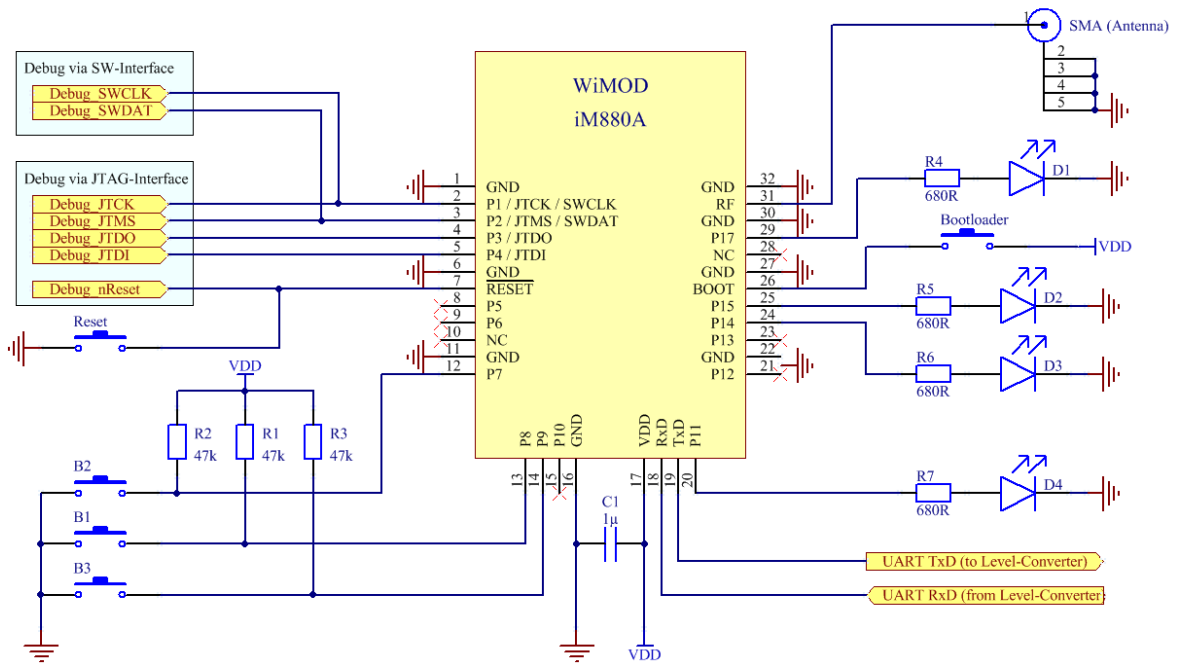

Figure 7-1: Typical Application Schematic for iM880A

## 7.2 PCB Design Recommendation

The Top Layer of the carrier board should be kept free of Tracks and Vias under the iM880A because there are some test pads on the bottom side of the module which are not covered by solder resist.

All GND pads of the module should be connected via low impedance path to GND.

The iM880A's RF interface is already matched to  $50 \Omega$ . By using an adequate  $50 \Omega$  antenna, no additional matching components are required<sup>1</sup>. For an ideal signal transmission between the module's RF pad and the antenna, the transmission line should be as short as possible and represent an impedance of  $50 \Omega$ .

**Note:** Disregarding this recommendation can affect the RF performance respective RF output power, sensitivity, and unwanted emissions.

This impedance depends on frequency and PCB structure. It is recommended to use a grounded coplanar waveguide (CPWG) structure, to reduce effects of electromagnetic fields. The impedance of transmission line for grounded CPWG is basically affected by height  $H$  and material of the substrate, gap  $G$  between transmission line and ground on the top layer, as well as width  $W$  and thickness  $T$  of the transmission lines (Figure 7-2).

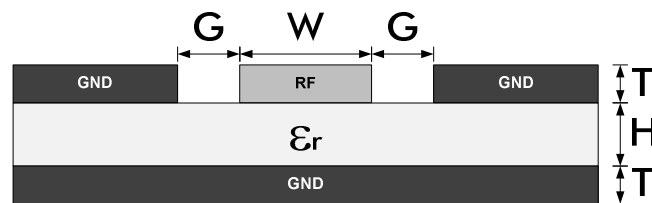

Figure 7-2: Structure of a grounded CPWG

<sup>1</sup> In other case a special matching network is required

Assuming a frequency of approx. 868 MHz, FR4 ( $\epsilon_r \approx 4.8$ ) as substrate material, copper as conductor material,  $G = 0.4$  mm and  $T = 35 \mu\text{m}$ , the width of transmission line is given by Table 7-1.

H [mm]	W [mm]
1.0	1.37
1.6	1.85

Table 7-1: Recommended width of transmission line for CPWG and 868 MHz

### 7.3 Recommended Soldering Conditions

An example of the temperature profile for the soldering process of the iM871A is depicted in Figure 7-3 with the corresponding values as given by Table 7-2. The temperature values should not exceed the limits.

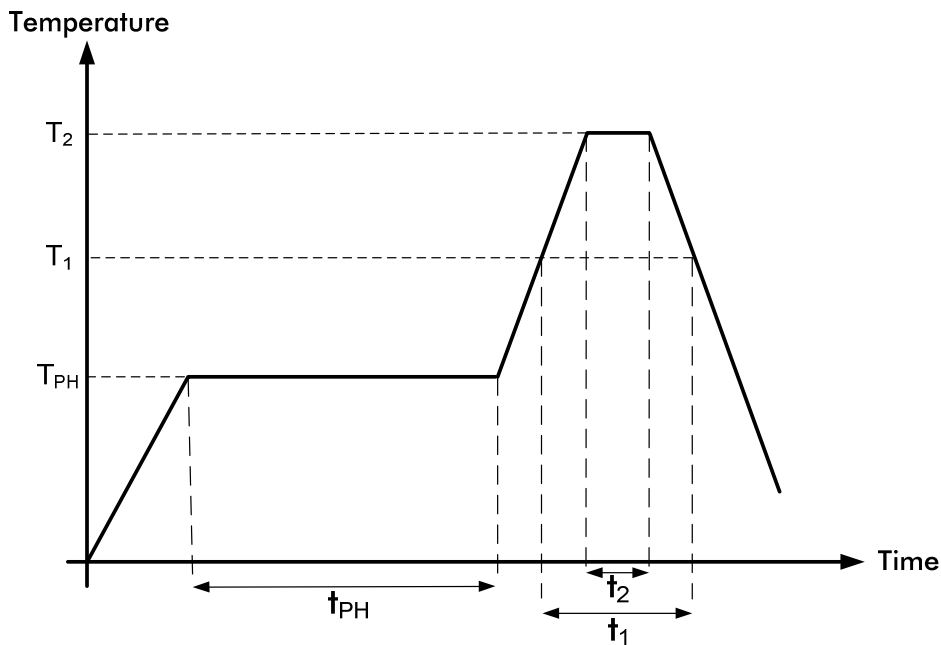

Figure 7-3: Soldering Profile

Phase	Pb-Free Conditions
Preheating	$t_{PH} = 120\text{s}$ $T_{PH} = 160\sim 180^\circ\text{C}$
Primary heat	$t_1 = 60\text{s}$ $T_1 = 220^\circ\text{C}$
Peak	$t_2 = 10\text{s (max)}$ $T_2 = 255^\circ\text{C}$

Table 7-2: Recommended Soldering Parameter for Temperature and Timing

**Note:** The quality of the soldering process depends on several parameters, e.g. soldering paste, carrier board design, fabrication equipment,...

## 8. Ordering Information

Ordering Part Number	Description	Distributor
iM880A-M	Radio Module 64 KB Flash, 10 KB RAM	<a href="mailto:wimod@imst.de">wimod@imst.de</a>
iM880A-L	Radio Module 128 KB Flash, 16 KB RAM, 16 MHz MCU crystal	<a href="mailto:wimod@imst.de">wimod@imst.de</a>
SK – iM880A-L	Starter Kit for the iM880A. See Notes.	<a href="mailto:wimod@imst.de">wimod@imst.de</a>
AB – iM880A	2x Adapter Board with iM880A	<a href="mailto:wimod@imst.de">wimod@imst.de</a>
Notes: The Starter Kit contains two Demo Boards, two Adapter Boards with iM880A, two antennas, and a CD or USB memory stick with documentation.		

Table 8-1: Ordering Information

## 9. Appendix

### 9.1 List of Abbreviations

ADC	Analog-to-Digital Converter
BER	Bit Error Rate
BSC	Basic Spacing between Centers
CPWG	Coplanar Waveguide
CW	Continuous Wave
GND	Ground
GPIO	General Purpose Input/Output
I <sup>2</sup> C	Inter-Integrated Circuit
MCU	Microcontroller Unit
PCB	Printed Circuit Board
RAM	Random Access Memory
RF	Radio Frequency
SMBus	System Management Bus
SMT	Surface Mounted Technology
SPI	Serial Peripheral Interface
TRX	Transceiver
USB	Universal Serial Bus

## 9.2 List of Figures

Figure 1-1: Picture of iM880A.....	4
Figure 2-1: Block Diagram of Radio Module iM880A.....	5
Figure 4-1: RF output power level and current consumption versus power stages from 1 to 20 @ room temperature .....	12
Figure 5-1: Description of iM880A module pins and top view.....	13
Figure 5-2: Outer Dimensions of the iM880A (top view) .....	16
Figure 5-3: Recommended footprint of the iM880A (top view) .....	16
Figure 7-1: Typical Application Schematic for iM880A.....	18
Figure 7-2: Structure of a grounded CPWG.....	19
Figure 7-3: Soldering Profile .....	20

## 9.3 List of Tables

Table 2-1: Typically Radio Performance of iM880A.....	5
Table 3-1: Spreading Factors of Sx1272 .....	6
Table 3-2: Coding Rate of iM880A .....	6
Table 4-1: Absolute Maximum Ratings .....	8
Table 4-2: General Characteristics .....	9
Table 4-3: Module Interface Characteristics.....	10
Table 4-4: Applicable Frequency Bands for Non-Specific Short Range Devices.....	11
Table 4-5: Transmitter RF Characteristics.....	12
Table 5-1: iM880A Pinout Table .....	15
Table 7-1: Recommended width of transmission line for CPWG and 868 MHz .....	20
Table 7-2: Recommended Soldering Parameter for Temperature and Timing .....	20
Table 8-1: Ordering Information .....	21

## 9.4 References

- [1] Semtech Sx1272 Data Sheet from [www.semtech.com](http://www.semtech.com)
- [2] REC Recommendation 70-03 "Relating to the use of Short Range Devices (SRD)", Tromsø 1997, CEPT ECC subsequent amendments 9 th October 2012
- [3] iM880A\_AN010\_SW-Development from [www.wirelss-solutions.de](http://www.wirelss-solutions.de)
- [4] iM880A\_AN012\_RFSettings from [www.wirelss-solutions.de](http://www.wirelss-solutions.de)



## 10. Regulatory Compliance Information

The use of radio frequencies is limited by national regulations. The radio module has been designed to comply with the European Union's R&TTE (Radio & Telecommunications Terminal Equipment) directive 1999/5/EC and can be used free of charge within the European Union. Nevertheless, restrictions in terms of maximum allowed RF power or duty cycle may apply.

The radio module has been designed to be embedded into other products (referred as "final products"). According to the R&TTE directive, the declaration of compliance with essential requirements of the R&TTE directive is within the responsibility of the manufacturer of the final product. A declaration of conformity for the radio module is available from IMST GmbH on request.

The applicable regulation requirements are subject to change. IMST GmbH does not take any responsibility for the correctness and accuracy of the aforementioned information. National laws and regulations, as well as their interpretation can vary with the country. In case of uncertainty, it is recommended to contact either IMST's accredited Test Center or to consult the local authorities of the relevant countries.

## 11. Important Notice

### 11.1 Disclaimer

IMST GmbH points out that all information in this document is given on an “as is” basis. No guarantee, neither explicit nor implicit is given for the correctness at the time of publication. IMST GmbH reserves all rights to make corrections, modifications, enhancements, and other changes to its products and services at any time and to discontinue any product or service without prior notice. It is recommended for customers to refer to the latest relevant information before placing orders and to verify that such information is current and complete. All products are sold and delivered subject to “General Terms and Conditions” of IMST GmbH, supplied at the time of order acknowledgment.

IMST GmbH assumes no liability for the use of its products and does not grant any licenses for its patent rights or for any other of its intellectual property rights or third-party rights. It is the customer’s duty to bear responsibility for compliance of systems or units in which products from IMST GmbH are integrated with applicable legal regulations. Customers should provide adequate design and operating safeguards to minimize the risks associated with customer products and applications. The products are not approved for use in life supporting systems or other systems whose malfunction could result in personal injury to the user. Customers using the products within such applications do so at their own risk.

Any reproduction of information in datasheets of IMST GmbH is permissible only if reproduction is without alteration and is accompanied by all given associated warranties, conditions, limitations, and notices. Any resale of IMST GmbH products or services with statements different from or beyond the parameters stated by IMST GmbH for that product/solution or service is not allowed and voids all express and any implied warranties. The limitations on liability in favor of IMST GmbH shall also affect its employees, executive personnel and bodies in the same way. IMST GmbH is not responsible or liable for any such wrong statements.

Copyright © 2015, IMST GmbH

### 11.2 Contact Information

IMST GmbH

Carl-Friedrich-Gauss-Str. 2-4  
47475 Kamp-Lintfort  
Germany

T +49 2842 981 0

F +49 2842 981 299

E [wimod@imst.de](mailto:wimod@imst.de)

I [www.wireless-solutions.de](http://www.wireless-solutions.de)

